



Scotchkote™

323/323i Liquid Epoxy Coatings

Data Sheet and Application Instructions

Product Description

3M™ Scotchkote 323/323i Liquid Epoxy Coatings are two-part systems designed to protect steel pipe and other metal surfaces from the harsh affects of corrosion.

Intended Uses

- As a patch material.
- As a girthweld coating.
- As an internal lining
- As a stand alone coating for pipe rehabilitation.
- In a wide variety of other field applications where corrosion protection of metal is required.

Product Features

- No solvents needed.
- High build, up to 45 mils/1150 microns in one application.
- Applicable by cartridge, brush, roller or plural component spray.
- Excellent adhesion.
- 100% solids.
- Can be applied to a substrate as cold as 41°F/5°C.
- Meets the requirements of AWWA C210, - 97 clause 4.3.4.1.
- Certified to ANSI/NSF Standard 61, Drinking Water System Components.



Chemical Resistance

Scotchkote 323/323i are resistant to damage by acids and bases in the pH range of 2 to 14. It is also resistant to hydrocarbons such as crude oil, motor oil, gasoline and many solvents. Testing is suggested if the coating is to be used in continual contact with oxidizing agents such as sodium hypochlorite (bleach) and aggressive solvents such as methyl ethyl ketone (MEK).

3M™ Scotchkote™ 323/323i Coverage per kit size				
Assumes no waste				
Kit	lbs of material	Coverage in square feet @mils		
		25	28	30 mils
	Total	25	28	30 mils
50 ml	0.15	0.85	0.76	0.71
400ml	1.19	6.78	6.05	5.65
Quart	2.1	11.9	10.6	9.9
Gallon	8.7	47.7	42.6	39.7
5 gal x 3	152.1	865.8	773.0	721.5
55 gal-drum x 3	1,690.4	9,621.8	8,590.9	8,018.1

General Application Steps

For use as a joint coating, a refurbishing coating or as a pipe coating:

1. Remove oil, grease and loosely adhering deposits.
2. Abrasive blast clean the surface to NACE No. 2/SSPC-SP10, ISO 8501:1, Grade SA 2 1/2 near-white metal.
3. Ensure the abraded surface is cleaned of abrading debris with the use of an air blast or a clean lint free cloth.
4. Within four hours of blasting as per the above cleaning process and with the metal above 41°F/5°C and a minimum of 5°F/3°C above the dew point, apply Scotchkote 323/323i at a minimum thickness of 635 microns or 25 mils.
5. Allow to cure.
6. Visually or electrically inspect the coating for defects.
7. Repair all defects using Scotchkote 323/323i as a repair material.

For use as a repair material in the field where scratches or other holidays may have occurred as a result of shipping damage, etc., and the bare area of steel substrate exposed exceeds approximately 20 mm diameter or about 0.6 sq. in. or 400 sq. mm:

1. Remove oil, grease and loosely adhering deposits.
2. Abrade the FBE surface with medium grit sandpaper (approximately 80 grit). Powered rotary sanders are an acceptable means to perform this task. Ensure that the surrounding FBE is roughened for 10 mm on all sides. An anchor pattern of 40 to 100 microns is preferred on the substrate.
3. Ensure the abraded surface is cleaned of abrading debris with the use of an air blast or a clean lint free cloth.
4. With the metal above 41°F/5°C and a minimum of 5°F/3°C above the dew point, apply Scotchkote 323/323i at a minimum thickness of 635 microns or 25 mils.

Number of U.S. Quarts/.95 L needed per weld

Pipe Diameter (inches)	Total Length to coat (cut backs + overlaps)			
	6"/15 cm	8"/20 cm	10"/25 cm	12"/30 cm
6	0.06	0.08	0.10	0.13
12	0.13	0.17	0.21	0.25
20	0.21	0.28	0.35	0.42
24	0.25	0.33	0.42	0.50
30	0.31	0.42	0.52	0.63
36	0.38	0.50	0.63	0.75
42	0.44	0.59	0.73	0.88
48	0.50	0.67	0.84	1.00

Properties

Properties	Value
Color	Blue-Green
Mix Ratio	2A : 1B by volume 70.8% : 29.2% by weight
Viscosity in cps @ • Brush Grade • Spray Grade	72°F/22°C 323 Part A: 154,000 Part B: 6,000 Part A: 90,000 Part B: 19,000
Viscosity in cps @ • Brush Grade • Spray Grade	72°F/22°C 323i Part A: 154,000 Part B: 3,500 Part A: 90,000 Part B: 9,500
Shelf Life (unopened container)	24 months
Specific Gravity	1.35 mixed
Coverage	142 sq ft/lb/mil (0.74m ² /kg/mm)
Max Operating Temperature • Wet • Dry	203°F/95°C 250°F/121°C
Minimum Coating Thickness	25 mils/635 microns recommended

Typical Test Properties

Property	Test Description	Typical Value
Shyodu Gel Time (approximate pot life)	200 gm mass	75°F / 24°C 18 min
		104°F / 40°C 11 min
Dry to Touch Time	ASTM D1640 clause 7.5.2	41°F / 5°C 7 hrs
		75°F / 24°C 1 hr 45 min
		122°F / 50°C 26 min
Approximate Back Fill Time (For additional information see chart below)	ASTM D1640 clause 7.7.1	41°F / 5°C 8 hrs
		75°F / 24°C 2 hr 39 min
		122°F / 50°C 39 min
Cathodic Disbondment (steel grit blasted plates laboratory applied; results may vary depending on blast media)	CSA Z245.20-02 clause 12.8	149°F / 65°C, 3.5V, 24 hrs 4.9 mmr
		149°F / 65°C, 1.5V, 48 hrs 5.5 mmr
		149°F / 65°C, 1.5V, 28 days 7.5 mmr
		176°F / 80°C, 1.5V, 14 days 6.4 mmr
		176°F / 80°C, 1.5V, 28 days 6.6 mmr
Adhesion of Coating	CSA Z245.20-02 clause 12.14	203°F / 95°C 24 hrs Rating 1
		167°F / 75°C 48 hrs Rating 1
		167°F / 75°C 28 days Rating 1
Flexibility	CSA Z245.20-02 clause 12.11	68°F / 20°C 0.7 °/PD
		32°F / 0°C 0.7 °/PD
Abrasion Resistance	ASTM D4060-95 CS-17 wheels 1000 g load 5000 cycles wheels resurfaced every 500 cycles	0.325 g loss
Impact Strength	ASTM G14	323 = 73.6 inch-lbs (8.3 Joules) at 75°F / 24°C 323i = 60.9 inch-lbs (6.8 Joules) at 75°F / 24°C
Impact Resistance	CSA Z245 20-98 Clause 12.12	See Chart Below

Impact value is the last Joule where three impacts have passed

Panel Number	Test Temperature	Joule Value	Holiday detection voltage	Average DFT (mils)
1	-40°F/-40°C	1.5	2500	30.4
2	-22°F/-30°C	1.0	2500	24.5
3	14°F/-10°C	1.5	2500	27.2
4	32°F/0°C	1.5	2500	25.0
5	68°F/20°C	2.75	2500	26.9
6	122°F/50°C	2.5	2500	27.7
7	149°F/65°C	4.0	2500	27.0
8	176°F/80°C	3.5	2500	26.3

Shore D Hardness vs. Time and Temperature

Time	10°C (50°F)	20°C (68°F)	30°C (86°F)	40°C (104°F)
1 hour	--	--	--	--
1.5 hours	--	--	--	72
2 hours	--	--	--	76
2.5 hours	--	--	72	79
3 hours	--	72	76	79
3.5 hours	--	73	78	79
4 hours	--	75	80	79
4.5 hours	--	76	81	80
5 hours	--	77	82	82
5.5 hours	--	79	82	82
6 hours	--	80	82	81
6.5 hours	--	81	83	81
7 hours	72	82	83	82
7.5 hours	73	82	83	81
8 hours	73	83	84	83
9 hours	74	83	83	81
17 hours	82	85	84	84
3 days	85	85	85	85

323/323i Brush Grade Application Instructions

1. Mix separate parts A and B.
2. Pour part B into part A. Scotchkote 323/323i have a mix ratio of 2A to 1B by volume.
3. Thoroughly mix combined parts into a uniform color.

Pot Life (Approximate)

200 gm mass	
75°F (24°C)	20 minutes
104°F (40°C)	11 minutes

Recommendations

- Prepare only the quantity of coating that can be applied in this period of time within the pot life.
- A 1/4" (6 mm) nap roller is suggested.
- For speed of application, and to extend the working life of the product, pour mixed product directly to the top of the substrate/pipe, then pull the mixture down around pipe in one direction with brush.
- Because of the high viscosity of this product, we suggest mixing parts A & B together at temperatures above 68°F (20°C).

Using a brush or roller, apply Scotchkote 323/323i to a minimum thickness of 25 mils (635 µm) or as specified. Overlap the pipe coating no less than 1" (25 mm). Allow coating to properly cure before handling.

Scotchkote 323/323i Patch Compound Applicator

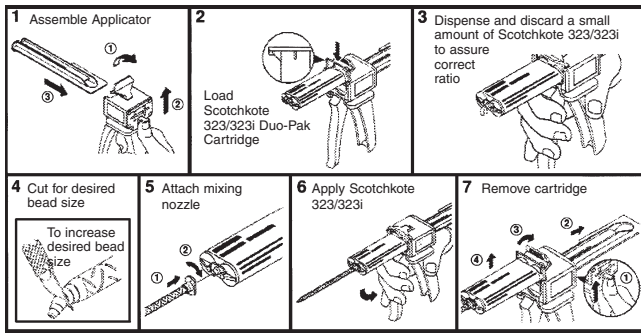

Multiple Coats

Scotchkote 323/323i have been formulated to achieve a coating thickness of up to 45 mils/1150 microns in one coat. If additional thickness is required, apply the additional coats within four hours of the initial coat. This coating may be applied in any thickness consistent with producing an acceptable surface finish.

Helpful Spray Information

- Suggested tip size of 625.
- Tip pressure approximately 2,200 psi/15.2 MPa.
- Preheat Part A to 150°F / 66°C.
- Preheat Part B to 120°F / 49°C.
- Mix ratio of pumps is 2:1.

Equipment Clean-Up

MEK or toluene may be used to clean spray equipment, rollers and brushes. Utilize proper safety guidelines.

Handling & Safety Precautions

Read all Health Hazard, Precautionary, and First Aid statements found in the Material Safety Data Sheet, and/or product label prior to handling or use.

Important Notice

All statements, technical information, and recommendations related to 3M's products are based on information believed to be reliable, but the accuracy or completeness is not guaranteed. Before using this product, you must evaluate it and determine if it is suitable for your intended application. You assume all risks and liability associated with such use. Any statements related to the product which are not contained in 3M's current publications, or any contrary statements contained on your purchase order shall have no force or effect unless expressly agreed upon, in writing, by an authorized officer of 3M.

Ordering Information/Customer Service

For ordering technical or product information, or a copy of the Material Safety Data Sheet, call:
Phone: 800/722-6721 or 512/984-9385
Fax: 877/601-1305 or 512/984-6296

Warranty; Limited Remedy; Limited Liability.

This product will be free from defects in material and manufacture for a period of one 24 months from the time of purchase. **3M MAKES NO OTHER WARRANTIES INCLUDING, BUT NOT LIMITED TO, ANY IMPLIED WARRANTY OF MERCHANTABILITY OR FITNESS FOR A PARTICULAR PURPOSE.** If this product is defective within the warranty period stated above, your exclusive remedy shall be, at 3M's option, to replace or repair the 3M product or refund the purchase price of the 3M product. **Except where prohibited by law, 3M will not be liable for any indirect, special, incidental or consequential loss or damage arising from this 3M product, regardless of the legal theory asserted.**

3M

Corrosion Protection Department

6801 River Place Blvd.
Austin, TX 78726-9000
www.3M.com/corrosion

Please recycle. Printed in USA.
© 3M 2007. All rights reserved.
80-6111-8345-2-J